

FLOWSERVE
™

Valtek ShearStream
Control Valves

Valtek ShearStream Control Valves

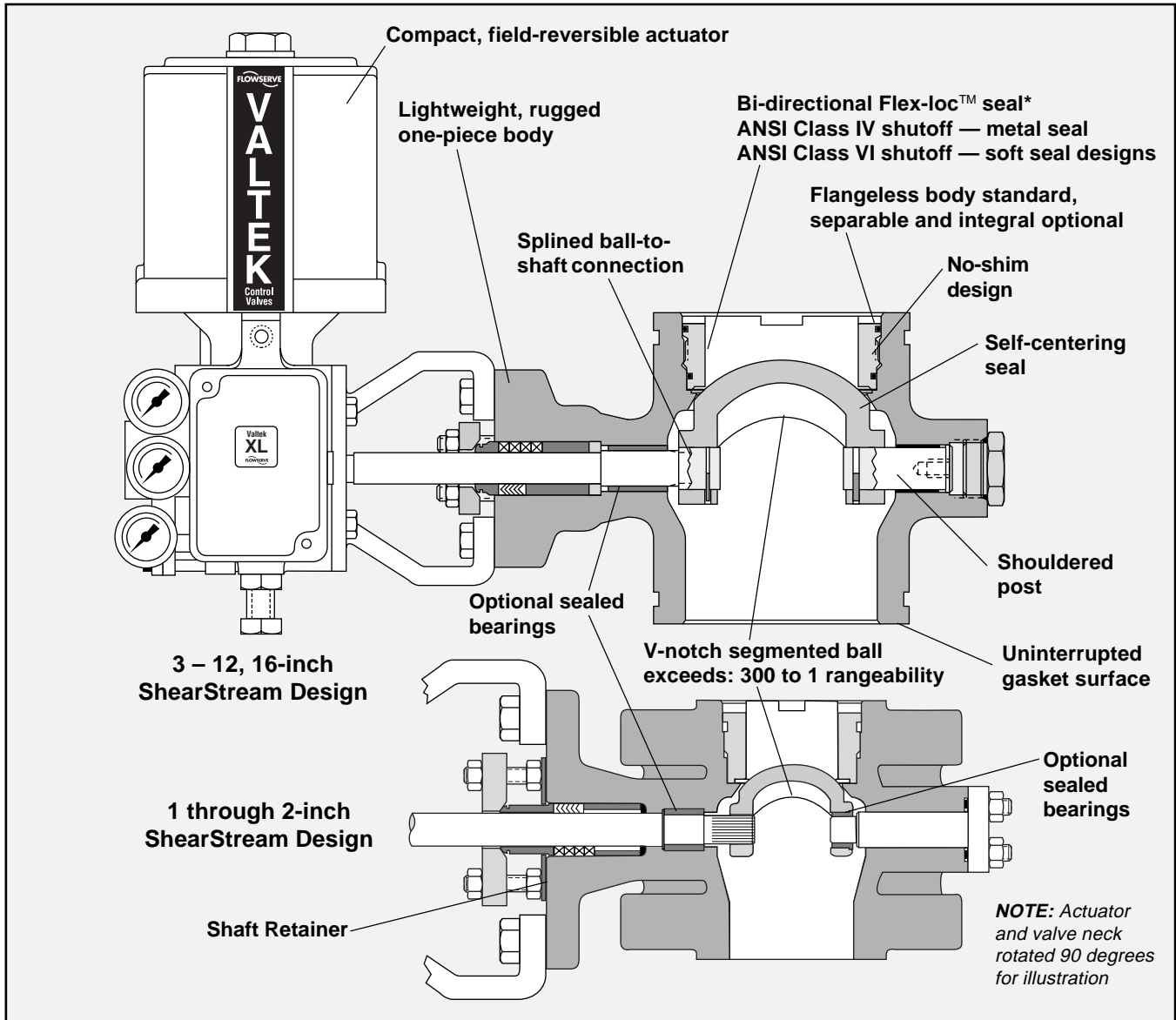

Figure 1: ShearStream Design

“Rugged” describes the Valtek® ShearStream™ ball valve. Designed to overcome the problems of harsh, particle entrained processes, ShearStream also provides accurate, reliable control in a broad range of applications, such as chemical, power and petroleum.

ShearStream addresses and solves many long-standing challenges faced by traditional ball valves, such as:

- Piping forces that unevenly load the seal
- Low rangeability due to limited orifice characterization
- Unsatisfactory shutoff capabilities

ShearStream achieves Class IV shutoff with a metal seal and Class VI with the Flex-loc™* soft seal. In addition to the standard wafer body design, ShearStream is available with separable or integral flanges. ShearStream is available in sizes 1 through 12 and 16-inch, ANSI Classes 150, 300, and 600, and in stainless steel, carbon steel and other alloys. The following page lists many important features and options which ShearStream uses to fulfill these and other requirements for ruggedness and high-performance.

* patented

Valtek ShearStream Features and Advantages

ShearStream utilizes numerous features for ruggedness and high performance:

Features	Advantages
One-piece body	High performance ensured regardless of flange torque loads Seal tightness not altered by piping forces, as in two-piece bodies One leak path eliminated
Segmented V-notch ball	Clogging reduced “V” shaped orifice exceeds 300:1 rangeability Excellent shearing action in fibrous fluid mediums
Pressure assisted/bi-directional Flex-loc seal (patented)	Metal seal provides greater than ANSI Class IV shutoff Soft seals achieve ANSI Class VI shutoff
Self-centering seal	Seal installation improved and simplified Shutoff further improved
No-shim seal	Servicing and installation problems reduced
Thick-walled retainer	Valve’s normal service life extended in erosive environments
Flangeless design standard	Reduced cost
Separable flange option	Bolt length reduced, avoiding bolt stretch and leakage in event of fire Flange bolting aligns easier Reduced cost with alloys
Integral flange option	Bolt length reduced, avoiding bolt stretch and leakage in event of fire

ShearStream has additional features for increased performance and serviceability:

Interchangeability	Standard face-to-face dimensions allow for easy field retrofitting of other manufacturers product lines Actuator is interchangeable with Valtek Valdisk™ eccentric disc valve
Seal replaceable without removing ball and shaft	Maintenance is fast and easy
Shaft serviceable from outboard end of ball (3 – 12, 16-inch only)	The need for actuator removal to replace ball and shaft is eliminated Shaft protected from blowout
Full, uninterrupted gasket surface	Gasket alignment problems reduced Wider range of gasketing possible, including spiral-wound

ShearStream also capitalizes on established features of Valtek quality:

Double acting, cylinder actuator	High-thrust, compact, lightweight Actuator fully interchangeable with Valdisk rotary valve actuator Actuator air pressures allowable up to 150 psi / 1034 kPa
Modular spool-type, four-way positioner	Calibration and maintenance are simple Convertible between pneumatic and electro-pneumatic
Clamped Splined shaft	Extra strength provided with no lost motion or dead band
Available in variety of materials	Materials include carbon steel, 316 stainless steel and other alloys

Each ShearStream feature contributes to a product measurably superior to other ball valves, as illustrated by the following pages which contain additional information and specifications.

Valtek ShearStream Standard Metal and Soft Seals

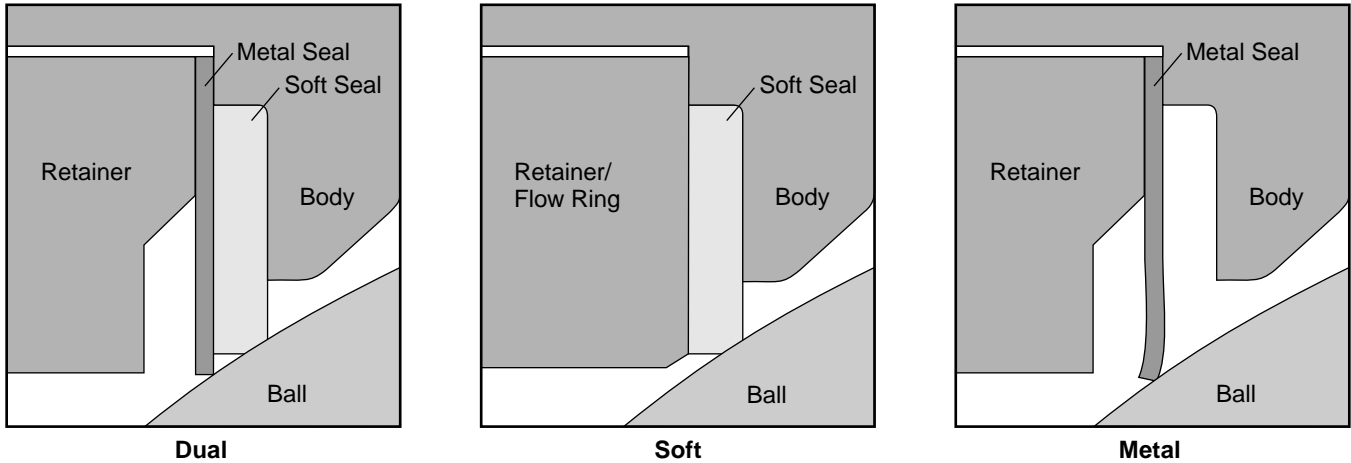

Figure 3: Standard Metal and Soft Seals

The standard soft seal design for ShearStream utilizes a 316 stainless steel or INCONEL metal seal and an additional PTFE or PEEK soft seal to provide ANSI Class VI shutoff. This seal design provides for back-up of the soft seal in case of failure and also provides for additional wiping and shearing capability. In some instances such as in alloy valves, a metal back-up seal cannot be used because of the potential for galling on an unhardened, uncoated ball. When this is the case, a special design is available called the alloy soft seal which

does not use a metal seal back-up. This seal can also be used in either flow direction and is recommended for use in oxygen or corrosive services where 316 stainless steel or Inconel 625 are not compatible with the process fluid or ball material.

Flow Rings

Hardened flow rings without a soft seal may be used in severe service applications. Flow rings can throttle flow to approximately 2 percent of valve capacity.

Bi-directional Metal Seals

Flex-loc Sealing

Flex-loc sealing uses the pressure drop across the seal to enhance its shutoff characteristics in either flow direction. It achieves ANSI Class IV with a metal seal. As differential pressure increases, Flex-loc uses the pressure to increase sealing capacity.

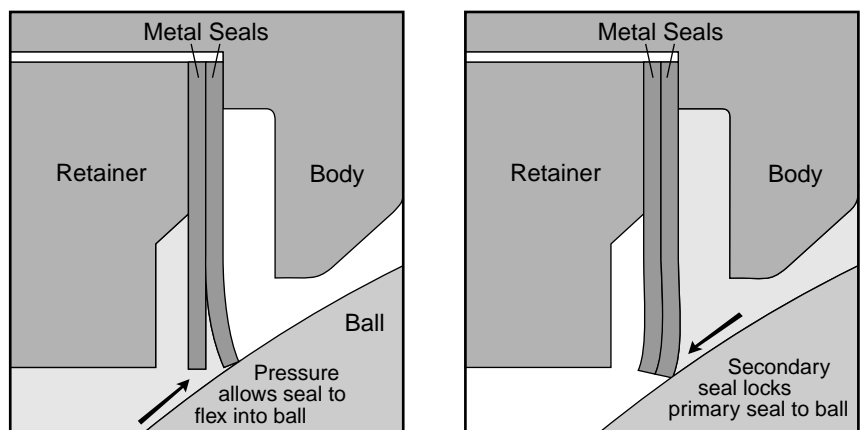

Figure 4: Principles of Bi-directional Flex-loc Seal

The “Flex” Principle

As pressure enters the cavity with the shaft downstream, the flexible seal deflects into the ball, causing it to seal tighter against the ball.

The “Loc” Principle

As pressure enters the cavity with the shaft upstream, the secondary seal locks the primary seal against the ball, causing it to seal tighter against the ball.

Valtek ShearStream

Specifications

Table I: Material Selection

Part	Material
Body	Carbon Steel, 316 SS, 316L SS, 304 SS, 304L SS, Monel, Hastelloy C, Hastelloy B/B-2, Alloy 20, Titanium
Ball	Chrome Plated 317 SS, Stellite Facing, Chrome Plated 316L SS, Chrome Plated 304 SS, Chrome Plated 304L SS, Hastelloy C, Monel, Nickel Plated 317 SS, Alloy 20, Hastelloy B/B-2, Titanium
Shaft / Pin	17-4 PH, Nitronic 50, Nitronic 50/Stellite, Hastelloy C, K-Monel, Alloy 20, Hastelloy B/B-2, Titanium
Bearings	MBT, Stellite, Ultimet
Seat Ring	316 SS, Inconel
Soft Seat	Glass filed PTFE, PEEK, TEFZEL
Packing	TFE V-ring, QuickSet 9001, AFPI, SafeGuard, SureGuard, SureGuard XT, 1303 FEP, Graphite Rib/Braid, TFE/Glass V-ring
Seat Retainer	Chrome Plated 316 SS, 316 SS w/ Stellite, Chrome Plated 316L SS, 316L w/ Stellite, Chrome Plated 304 SS, Chrome Plated 304L SS, Monel, Hastelloy C, Alloy 20, Hastelloy B/B-2, Titanium
End Plug	Carbon Steel, 316 SS, 316L SS, 304 SS, 304L SS, Alloy 20, Hastelloy C, Hastelloy B/B-2, Monel, Titanium
End Seal	Viton O-ring, Graphite
Yoke Bolting	Carbon Steel, Stainless Steel

**Table II: Flow Coefficients
(Ball rotated 90°)**

Body Size (inch)	C _v at 90° Rotation	
	Shaft Downstream	Shaft Upstream
1	28	25
1.5	59	57
2	118	114
3	270	280
4	529	462
6	988	945
8	1800	1675
10	3320	3180
12	4150	4150
16	7120	7120

Table III: Seat Configurations

Seat Type	Description	Shaft Orientation	ANSI Leakage Class	Material	Maximum Temperature (° F / ° C)
Metal	One metal seat ring	Downstream	IV	316 SS	300 / 150
				Monel	400 / 204
				Inconel	600 / 315
Dual	One soft seat plus one metal backup seat	Upstream	VI	Filled-PTFE / Metal	350 / 177
Soft	One soft seat	Upstream	VI	Filled-PTFE	350 / 177
				PEEK	500 / 260
Bi-Directional Metal	Two metal seat rings	Upstream or Downstream	IV	316 SS	300 / 150
				Inconel	600 / 315
Flow Ring	No seat	Upstream or Downstream	II*	N/A	600 / 315

* Flow rings are intended for throttling applications. Leakage when fully closed is approximately ANSI Class II.

Valtek ShearStream

Dimensions

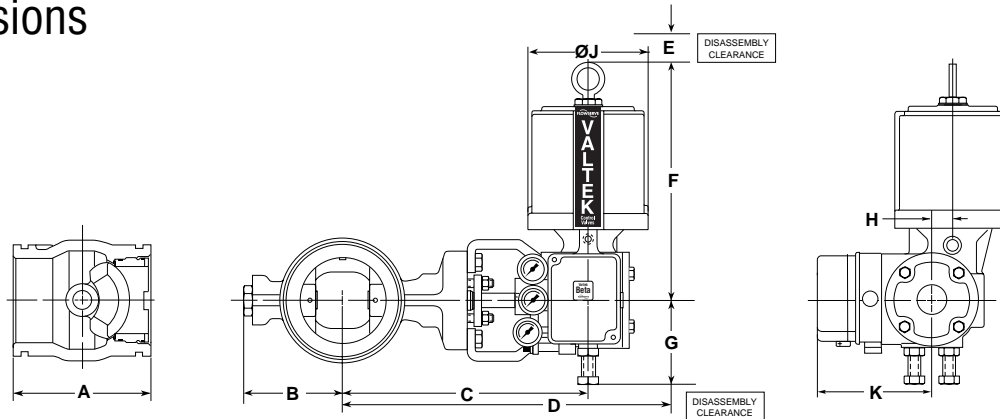
Table IV: ShearStream Dimensions (inches/mm)

Body Classes 150, 300, 600 (with Class 150 or 300 ball and shaft)																						
Valve Size	Actuator Size*	Spline Size*	A		B		C		D		E		F		G		H		J		K	
1	25	0.44	4.00	101.6	3.3	85	10.6	269	21.2	538	5.3	135	13.3	338	4.5	114	1.1	28	6.5	165	6.5	165
1½	25	0.62	4.50	114.3	3.9	99	11.1	282	21.7	551	5.3	135	13.3	338	4.5	114	1.1	28	6.5	165	6.5	165
2	25	0.62	4.94	125.5	4.3	109	11.4	290	22.0	559	5.3	135	13.3	338	4.5	114	1.1	28	6.5	165	6.5	165
3	25	0.75	6.50	165.1	5.0	127	12.5	318	23.1	587	5.3	135	13.3	338	4.5	114	1.1	28	6.5	165	6.5	165
	50	0.75	6.50	165.1	5.0	127	12.5	318	23.3	592	7.5	191	18.3	465	5.8	147	2.0	51	9.1	231	7.4	188
4	25	0.75	7.62	193.5	5.5	140	13.7	348	24.3	617	5.3	135	13.3	338	4.5	114	1.1	28	6.5	165	6.5	165
	50	0.75	7.62	193.5	5.5	140	13.7	348	24.5	622	7.5	191	18.3	465	5.8	147	2.0	51	9.1	231	7.4	188
6	25	0.88	9.00	228.6	7.9	201	15.9	404	26.5	673	5.3	135	13.3	338	4.5	114	1.1	28	6.5	165	6.5	165
	50	0.88	9.00	228.6	7.9	201	15.9	404	26.7	678	7.5	191	18.3	465	5.8	147	2.0	51	9.1	231	7.4	188
	100	0.88	9.00	228.6	7.9	201	15.9	404	30.2	767	8.5	216	22.9	582	7.5	191	2.4	61	12.5	318	8.4	213
8	50	0.88	9.62	244.3	8.7	221	16.7	424	33.5	851	7.5	191	18.3	465	5.8	147	2.0	51	9.1	231	7.4	188
	100	0.88	9.62	244.3	8.7	221	16.7	424	37.0	940	8.5	216	22.9	582	7.5	191	2.4	61	12.5	318	8.4	213
10	50	1.12	11.70	297.2	11.0	279	17.7	450	28.5	724	7.5	191	18.3	465	5.8	147	2.0	51	9.1	231	7.4	188
	100	1.12	11.70	297.2	11.0	279	17.7	450	32.0	813	8.5	216	22.9	582	7.5	191	2.4	61	12.5	318	8.4	213
	200	1.12	11.70	297.2	11.0	279	17.7	450	34.5	876	9.0	229	24.3	594	7.5	191	2.4	61	17.5	445	8.4	213
12	100	1.50	13.30	337.8	12.0	305	17.7	450	32.0	813	8.5	216	22.9	582	7.5	191	2.4	61	12.5	318	8.4	213
	200	1.50	13.30	337.8	12.0	305	17.7	450	34.5	876	9.0	229	24.3	594	7.5	191	2.4	61	17.5	445	8.4	213
16	100	1.75	15.80	400.0	16.6	422	26.1	663	42.0	1067	8.5	216	22.9	582	7.5	191	2.4	61	12.5	318	8.4	213
	200	1.75	15.80	400.0	16.6	422	26.1	663	44.5	1130	9.0	229	24.3	594	7.5	191	2.4	61	17.5	445	8.4	213

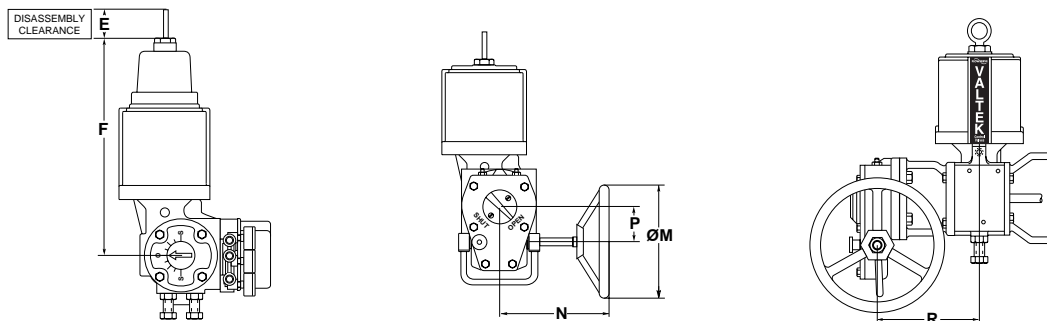
Table V: Handwheel and Extended, Heavy-duty Spring Dimensions (inches/mm)

Actuator Size (sq. in.)	E		F		M		N		P		R	
25	9.3	236	17.3	439	10.0	254	9.8	249	2.6	66	7.4	188
50	9.8	249	23.8	605	12.0	305	10.3	262	3.4	86	10.1	257
100	8.5	216	23.0	584	18.0	457	13.3	338	5.4	137	9.7	246
200	9.0	229	24.3	617	18.0	457	13.3	338	5.4	137	9.7	246

Valtek ShearStream

Specifications

Table VI: Estimated Shipping Weights with Standard Actuator and Positioner

Valve Size (inch)	Flangeless Body		Flanged Body*	
	(lb.)	(kg.)	(lb.)	(kg.)
1	41	19	47	22
1½	45	21	55	25
2	47	22	59	27
3	61	28	80	36
4	80	36	111	50
6	146	66	197	89
8	186	84	266	121
10	278	126	400	181
12	496	225	653	296
16	908	412	1259	571

Allowable seat configurations for ShearStream control valves are set as a function of shaft orientation. Refer to Table III to determine seat type and shaft orientation.
*Estimates based on Class 300 flanges.

Table VII: End Connections

Size (inch)	ANSI Class	End Connection
1	150 – 600	Integral, Flangeless
1½	150 – 600	Integral, Flangeless
2	150	Integral, Flangeless
	300 – 600	Integral*, Flangeless
3	150 – 600	Separable, Integral, Flangeless
4	150 – 600	Separable, Integral, Flangeless
6	150 – 600	Integral, Flangeless
8	150 – 600	Integral, Flangeless
10	150 – 600	Integral, Flangeless
12	150 – 600	Integral, Flangeless
16	150 – 600	Integral

* ShearStream 2-inch, ANSI Class 300-600 integral flange bolt holes are threaded.

Table VIII: Valve Actuator Compatibility

Actuator Size (sq. in.)	Spring Size	Valve Size (inch)										
		1	1½	2	3	4	6	8	10	12	16	
25	Std.	■	■	■	■	■	■					
	Extd.	■	■	■	■	■	■					
50	Std.				■	■	■	■	■			
	Extd.				■	■	■	■	■			
100	Std.						■	■	■	■	■	■
	Dual						■	■	■	■	■	■
200	Std.								■	■	■	■
	Dual								■	■	■	■

Table IX: Additional Specifications

Characteristic: Equal Percent / Linear (characterization with positioner)
Ball Rotation: Counterclockwise to open when viewed from actuator

ShearStream Sizing

Procedures and data to size ShearStream valves including determining actuator size, are contained in *Performance!* valve selection software.

Valtek ShearStream

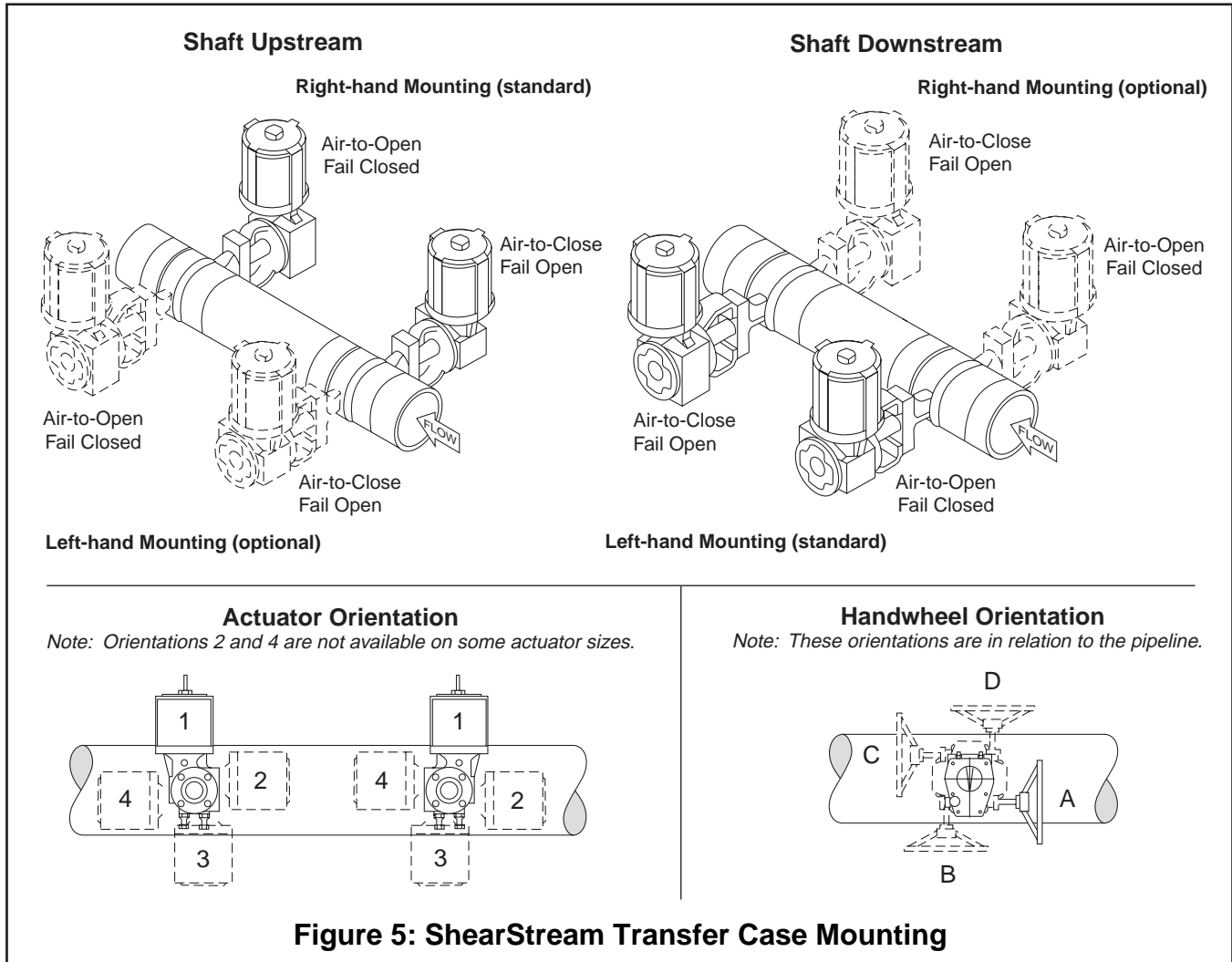

Figure 5: ShearStream Transfer Case Mounting

Flowserve Corporation has established industry leadership in the design and manufacture of its products. When properly selected, this Flowserve product is designed to perform its intended function safely during its useful life. However, the purchaser or user of Flowserve products should be aware that Flowserve products might be used in numerous applications under a wide variety of industrial service conditions. Although Flowserve can (and often does) provide general guidelines, it cannot provide specific data and warnings for all possible applications. The purchaser/user must therefore assume the ultimate responsibility for the proper sizing and selection, installation, operation and maintenance of Flowserve products. The purchaser/user should read and understand the Installation Operation Maintenance (IOM) instructions included with the product, and train its employees and contractors in the safe use of Flowserve products in connection with the specific application.

While the information and specifications presented in this literature are believed to be accurate, they are supplied for informative purposes only and should not be considered certified or as a guarantee of satisfactory results by reliance thereon. Nothing contained herein is to be construed as a warranty or guarantee, express or implied, regarding any matter with respect to this product. Because Flowserve is continually improving and upgrading its product design, the specifications, dimensions and information contained herein are subject to change without notice. Should any question arise concerning these provisions, the purchaser/user should contact Flowserve Corporation at any of its worldwide operations or offices.

For more information, contact:

For more information about Flowserve, contact www.flowserve.com or call USA 972 443 6500

Regional Headquarters

1350 N. Mt. Springs Prkwy.
Springville, UT 84663
Phone 801 489 8611
Facsimile 801 489 3719

12, av. du Québec, B.P. 645
91965, Courtaboeuf Cedex,
France
Phone (33 1) 60 92 32 51
Facsimile (33 1) 60 92 32 99

104 Chelsea Parkway
Boothwyn, PA 19061 USA
Phone 610 497 8600
Facsimile 610 497 6680

12 Tuas Avenue 20
Republic of Singapore 638824
Phone (65) 862 3332
Facsimile (65) 862 4940

Quick Response Centers

5114 Railroad Street
Deer Park, TX 77536 USA
Phone 281 479 9500
Facsimile 281 479 8511

1300 Parkway View Drive
Pittsburgh, PA 15205 USA
Phone 412 787 8803
Facsimile 412 787 1944

Flowserve and Valtek are registered trademarks of Flowserve Corporation.

