



Durco[®] *BTV-2000 Valve*

LINED CHEMICAL SERVICE VALVES



Quality
System
Certificate

Valve Technology for the 21st Century

PED 97/23/CE Compliant
Pressure Equipment Directive

Durco BTV-2000

Features Cost Effective Super Safe Performance

An important product from Flowserve...the Company that introduced the CPI's first fluoropolymer lined butterfly valve in 1965!

Extra wide spheroidal seat design provides positive shutoff.

One-piece 1/8 in (3 mm) thick (nominal) PFA or UHMWPE encapsulated disc locked onto nickel-plated ductile iron substrate... or choose from a wide variety of alloys.

1/8 in (3 mm) thick (nominal) rigid machined PTFE or UHMWPE liner is recessed in body preventing cold flow and facilitating installation.

Disc swing is compatible with ASTM F423-82 fluoropolymer lined pipe.

ASTM A395 ductile cast iron split body provides easy rebuild.

Popular "double-D" shaft drive provides positive valve position indication and simplifies adaption to automatic operation.

Interchangeable actuator mounting plate accommodates ISO, MSS or special actuators.

10-position locking lever and throttle plate or gear operated options are available.

Epoxy coated body and mounting plate resist the effect of atmospheric corrosion.

High strength B7 fasteners contain the shaft seal and bearing assembly while fighting atmospheric corrosion.

Notches on wafer or full lug body result in precise centering between flanges.

Wafer or lug body is rated to 150 psi.

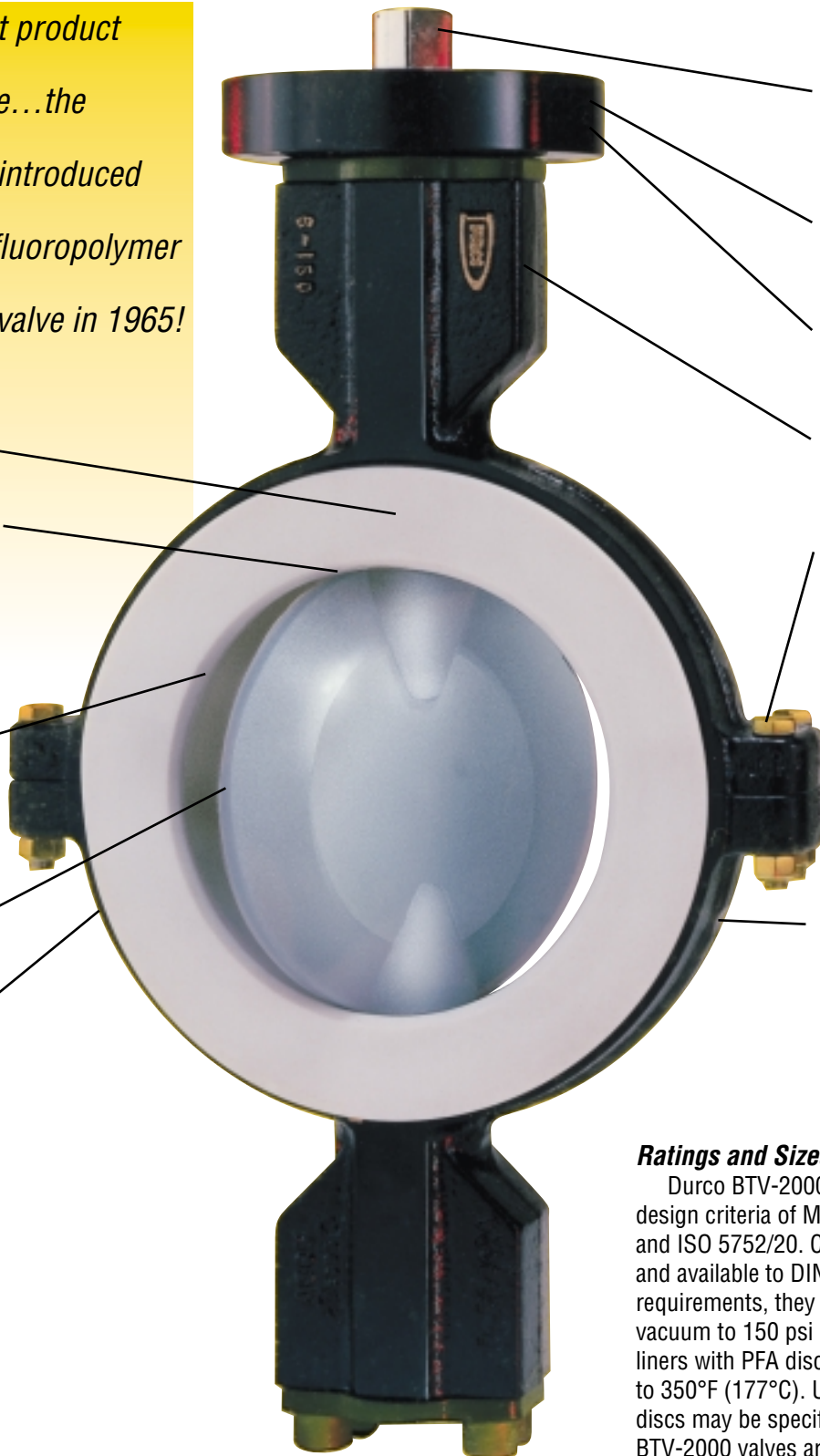

Ratings and Sizes

Durco BTV-2000 valves meet the design criteria of MSS SP67, API 609 and ISO 5752/20. Conforming to ASME and available to DIN PN10 and PN16 requirements, they are rated from full vacuum to 150 psi (1034 kPa). PTFE liners with PFA discs may be specified to 350°F (177°C). UHMWPE liners and discs may be specified to 200°F (93°C). BTV-2000 valves are available in sizes 2 in (50 mm) through 24 in (600 mm).

Ideal for Applications Requiring Stem Sealing Assurance

Maintenance Free, Live Loaded Triple Seal Design Assures Bubble Tight Shutoff Stem Seals

Dynamically energized shaft seals provide super safe operation.

BTV-2000 provides triple stem seal protection. The primary seal is formed at the disc hub by the spherical ball and socket disc/liner seal. An independent secondary seal of PTFE covered PFA convolutions on the disc stem enhances sealing with its "tortuous" no-leak path design. Finally, the O-rings in the alloy gland follower offer added protection from external media corrosion as well as preventing leakage to the atmosphere.

Leak tight sealing is further assured by a compression spring which keeps the dynamic pre-load force constant while energizing the various components of the triple shaft seal design.

This dynamic live loaded shaft seal never needs adjustment.

Unique, energized seat design results in bubble tight shutoff.

The spherical ball and socket disc/liner design provides a 360° contact seat seal. The rounded radius of the disc fits into the socket of the machined liner and stays in constant contact with the seat. The liner itself is recessed into the valve body for added stability and to prevent possible leakage due to cold flow or improper valve installation.

A live loaded elastomer seat energizer enhances sealing. Isolated and protected in the grooved valve body, the elastomer energizer operates independently of mating flange torque for constant line seal performance.

A wide choice of materials for the toughest service conditions.

There is a PTFE liner for severely corrosive chemical services...or UHMWPE for tough corrosion-erosion applications.

A one-piece PFA encapsulated disc (with a DCI/ENC substrate) is standard for chemical services. An UHMWPE encapsulated disc may be specified when abrasion resistance is needed.

A wide variety of optional metallic discs are available ranging from 316 stainless steel, Durimet 20 and 254 SMO¹ to Monel,² Chlorimet 2 & 3 and palladium stabilized titanium.

Unequaled performance in high temperature/high cycle services.

Heavy duty design of both components and materials enables the use of BTV-2000 valves with total confidence even in the most difficult operating conditions.

¹Registered trademark of Avesta AB.

²Registered trademark of the International Nickel Company.

Viton® O-rings provide atmospheric seal

Optional NPT connections for sealing lubricant, inert gas pad, purge or leak detection

PTFE filled composite bearing

Convolutions create tortuous no-leak path for enhanced independent secondary shaft seal

PTFE to PFA (or PTFE to alloy) stem seal

Machined spherical ball & socket disc/liner seal and primary shaft seal

Blow out-proof stem

Tamper-proof fasteners for personnel safety

Alloy gland follower

Fully compressed spring keeps constant pre-load on PTFE seam seal

Alloy wedge ring

Elastomer compression ring

Elastomer seat energizer locked in by machined groove in body is not dependent upon mating flange for line seal

©Viton is a registered trademark of the DuPont Company.

Unequaled Quality from the World's Oldest and Largest Manufacturer of Fluoropolymer Lined Valves

Flowserve has been a pioneer in the application of fluoropolymer materials with chemical process equipment since the introduction of the first PTFE sleeved plug valve in 1948. Although primarily used for its lubricity, the corrosion resistant features of PTFE quickly became evident.



In 1965, Flowserve scored two more CPI firsts with the introduction of the T-Line,[®] a fully lined plug valve, and a PTFE lined chemical service butterfly valve.

Over the years, Flowserve has gained a worldwide reputation for the quality and integrity of its fluoropolymer lined products. Flowserve is simply unequaled in its processing and manufacturing capabilities.

The Flowserve Engineered Plastic Products Division (EPP) not only produces most of the fluoropolymer components used in BTV-2000 valves but also provides materials research and development. The Flow Control Division at Cookeville, TN has the experience and know-how to consistently manufacture fluoropolymer components and products of world class quality. Plus, its Valve Engineering laboratory possesses a full range of product development and performance testing capabilities.

Flowserve is one of the few valve manufacturers that has both the in-house materials expertise and processing technology to manufacture fluoropolymer lined valve products.

Optional UHMWPE liners and encapsulated discs offer superior abrasion resistance.

PTFE Liners

Flowserve offers a thick, one-piece PTFE liner that forms the seat, flange gaskets and stem seals. Using only virgin high grade PTFE resin, a unique molding process produces a high density billet resulting in minimum permeability. It is then machined into a finished liner, dye checked and spark tested at 20,000 volts to ensure the absence of pin holes and defects.

PTFE is used because it has optimum chemical resistance and a higher service temperature than FEP or synthetic elastomers. Other features of PTFE are its low coefficient of friction, and low absorption and swelling. These characteristics result in a constant seating torque, which is so critical in automated installations.

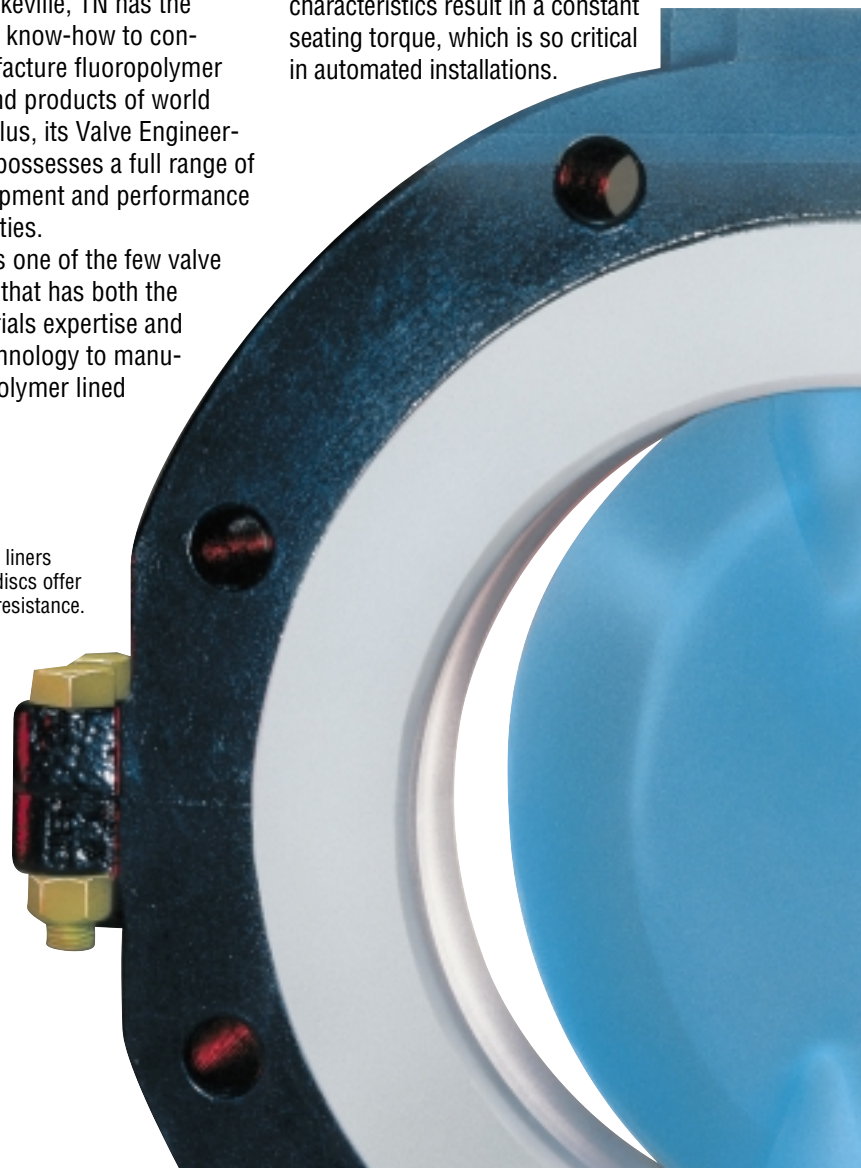

100% Tests

Every valve is spark tested and hydrostatically tested prior to shipment. The valve seat is tested at 150 psi (1034 kPa) while the stem seals are subjected to a 225 psi test. Each valve has a stainless steel tag giving figure number for identification and maintenance reference and complies with MSS SP25 for identification. All valves are fitted with covers to protect the fluoropolymer liner until installation.

Applications

PTFE lined BTV-2000 valves can be found throughout the CPI wherever chemical fluids are produced, processed, handled or disposed.

Some of the more typical services include:

- HCL
- HNO₃
- H₂SO₄
- Chlorinated brine
- Chlorinated organics
- Bleach
- Herbicides
- Pesticides
- Solvents
- White liquor
- Wet CL₂
- Electrogalvanizing solutions
- Sodium Chlorate
- CLO₂

UHMWPE Liners

Ultra high molecular weight polyethylene (UHMWPE) is a tough and durable polymer ideally suited for severe erosive services while offering good corrosion resistance. Flowserve's high density UHMWPE conforms to the specification ASTM D4020 which defines the parameters for "True" UHMWPE.

UHMWPE is a natural choice for media containing abrasive particles either with or without corrosive conditions. UHMWPE lined BUV-2000 valves are an excellent alternative and will consistently outperform rubber lined diaphragm, pinch, plug and gate valves.

For a more complete list of field proven PTFE lined BTV-2000 valve applications, contact your Flowserve sales representatives or staff personnel at the Flow Control Division in Cookeville, TN.

UHMWPE lined BUV-2000 valves perform cost effectively in the most severely erosive services.

When abrasive particles which would quickly destroy most metals and other non-metallics are present, BUV-2000 UHMWPE lined valves are the first choice. Typical applications include:

- Lime slurry
- Fly ash
- Caustic services
- Ferric chloride
- Titanium dioxide

Some additional industry and specific application examples are listed below.

Pulp and Paper Processing

- 20-30% solids, lime mud thickener underflow line to maximum temperature of 200°F (99°C).
- Unclarified green liquor, 175°F (79°C).
- White liquor clarifier bottoms, 165°F (74°C).

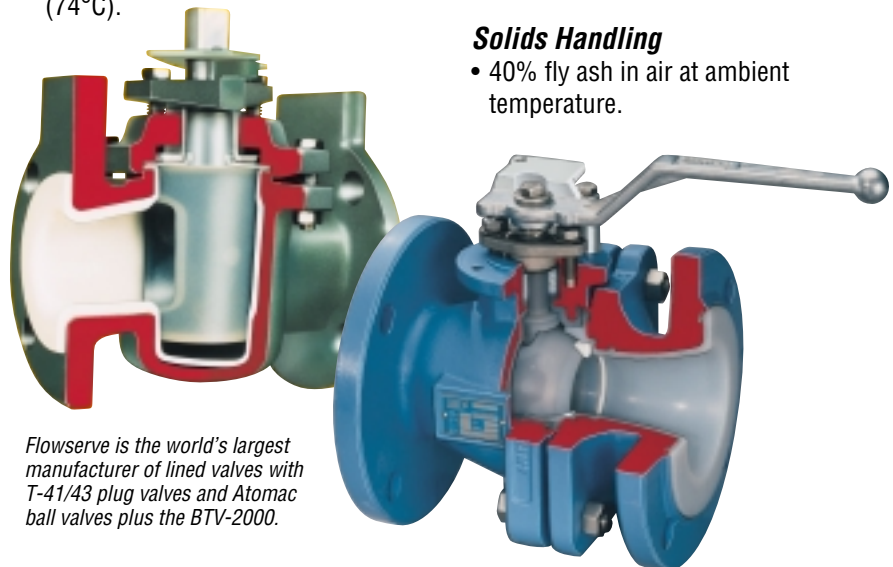

Flowserve is the world's largest manufacturer of lined valves with T-41/43 plug valves and Atomac ball valves plus the BTV-2000.

Mining and Metal Refining

- Zinc sulfate slurry, 165°F-194°F (75°C-90°C).
- Iron ore tailings from vacuum filter, 55-60% taconite (Fe₂O₃) solids.
- 50% Copper ore tailings in water, 105°F (41°C).

Chemical Processing

- Sodium chloride brine 20% solids by volume at 194°F (90°C).
- Calcium chloride brine at 175°F (79°C). (Application dependent upon no free CL₂ being present.)
- 10% Ammonium sulfate, 3% sulfuric acid at 194°F (90°C).
- 20% Titanium dioxide slurry, pH 3-7, 135°F (57°C).

Pollution Abatement

- Limestone scrubbing reaction product in electrical power plant, 15% solids by weight consisting of limestone, fly ash, calcium sulfate and calcium sulfite at 120°F (49°C).
- 15% fly ash slurry.
- 80% sodium bisulfite scrubber liquor at 140°F (60°C).
- Fume scrubber solution containing 8% sodium bisulfite at 140°F (60°C).

Solids Handling

- 40% fly ash in air at ambient temperature.

BTV-2000 Butterfly Valves Dimensions

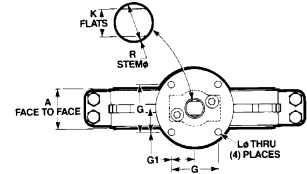
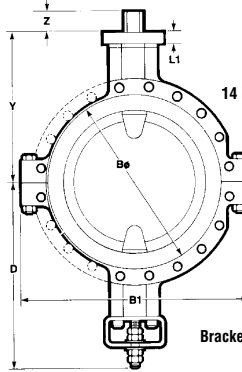
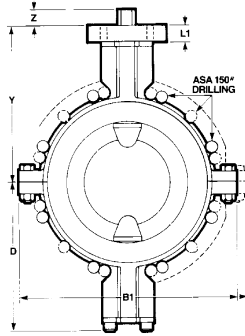
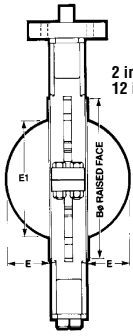

Bracket on 20 in (500 mm) & 24 in (600 mm) Sizes Only

Wafer Dimensions Only				
SIZE in (mm)	NO. OF FASTENERS	FASTENER HOLE in (mm)	B.C. in (mm)	B1 in (mm)
2 (50)	-	-	-	6 (152.4)
3 (80)	-	-	-	7 7/8 (200)
4 (100)	-	-	-	8 3/4 (222.3)
5 (125)	-	-	-	9 3/4 (247.7)
6 (150)	-	-	-	10 1/2 (266.7)
8 (200)	-	-	-	14 (355.6)
10 (250)	-	-	-	17 (431.8)
12 (300)	-	-	-	18 7/8 (479.4)
14 (350)	8	1 7/8 (28.5)	18 3/4 (476.3)	21 3/4 (552.5)
16 (400)	8	1 7/8 (28.5)	21 1/4 (539.8)	25 (635)
18 (450)	12	(4) 1 1/4 (31.7) (8) 1 1/8-8* (28.5)	22 3/4 (577.9)	26 3/4 (679.5)
20 (500)	12	(4) 1 1/4 (31.7) (8) 1 1/8-8* (28.5)	25 (635.0)	30 (762)
24 (600)	12	(4) 1 3/8 (34.9) (8) 1 1/4-8* (31.8)	29 1/2 (749.3)	36 (914.4)

Dimensions Common to BTV-2000 Wafer and Lug Valves												
A in (mm)	BØ in (mm)	D in (mm)	E in (mm)	E1 in (mm)	G in (mm)	G1 in (mm)	K in (mm)	LØ in (mm)	L1 in (mm)	RØ in (mm)	Y in (mm)	Z in (mm)
1 11/16 (42.8)	3 3/8 (92.0)	4 15/16 (125.4)	0.390 (9.90)	1.801 (45.74)	2 1/4 (57.1)	1 1/8 (28.5)	0.562 (14.27) 0.558 (14.17)	3/8 (9.5)	3/4 (19.0)	0.718 (18.23) 0.708 (17.98)	5 3/16 (131.7)	1 3/32 (27.7)
1 13/16 (46.0)	5 (127)	5 13/32 (137.3)	0.672 (17.06)	2.586 (65.68)	2 1/4 (57.1)	1 1/8 (28.5)	0.562 (14.27) 0.558 (14.17)	3/8 (9.5)	3/4 (19.0)	0.718 (18.23) 0.708 (17.98)	6 3/32 (159.5)	1 3/32 (27.7)
2 1/16 (52.3)	6 (152.4)	6 13/32 (162.7)	0.994 (25.24)	3.487 (88.56)	2 1/4 (57.1)	1 1/8 (28.5)	0.562 (14.27) 0.558 (14.17)	3/8 (9.5)	3/4 (19.0)	0.718 (18.23) 0.708 (17.98)	6 25/32 (172.2)	1 3/32 (27.7)
2 7/32 (56.3)	7 1/8 (181.0)	8 (203.2)	1 3/8 (34.9)	4 7/16 (112.7)	3 (76.2)	1 1/2 (38.1)	0.843 (21.41) 0.839 (21.31)	7/16 (11.1)	1 (25.4)	1.093 (27.76) 1.083 (27.50)	8 1/2 (215.9)	1 1/2 (38.1)
2 7/32 (56.3)	8 1/4 (209.5)	8 1/2 (215.9)	1.860 (47.24)	5.510 (139.9)	3 (76.2)	1 1/2 (38.1)	0.843 (21.41) 0.839 (21.31)	7/16 (11.1)	1 (25.4)	1.093 (27.76) 1.083 (27.50)	9 (228.6)	1 (25.4)
2 3/8 (60.3)	10 1/4 (260.3)	9 7/16 (239.7)	2.688 (68.27)	7.379 (187.4)	3 (76.2)	1 1/2 (38.1)	0.843 (21.41) 0.839 (21.31)	7/16 (11.1)	1 (25.4)	1.093 (27.76) 1.083 (27.50)	9 15/16 (252.4)	1 (25.4)
2 11/16 (68.2)	12 1/4 (311.1)	11 29/32 (302.4)	3.626 (92.10)	9.569 (243.0)	3 1/2 (88.9)	1 3/4 (44.4)	1.190 (30.22) 1.186 (30.12)	9/16 (14.2)	1 (25.4)	1.468 (37.28) 1.458 (37.03)	12 3/32 (311.94)	1 3/4 (44.5)
3 3/32 (78.5)	14 3/8 (365.1)	12 15/16 (328.6)	4.438 (112.7)	11.564 (293.7)	3 1/2 (88.9)	1 3/4 (44.4)	1.190 (30.22) 1.186 (30.12)	9/16 (14.2)	1 (25.4)	1.468 (37.28) 1.458 (37.03)	13 5/16 (338.14)	2 1/8 (53.98)
3 3/32 (78.5)	16 1/4 (412.7)	13 15/16 (354.0)	5.016 (127.4)	12.755 (323.9)	4 1/4 (107.95)	2 1/8 (53.98)	1.248 (31.7) 1.246 (31.65)	9/16 (14.2)	1 1/2 (38.1)	1.719 (43.66) 1.709 (43.41)	14 7/16 (366.71)	2 (50.8)
4 (101.6)	18 1/2 (469.9)	15 3/16 (385.7)	5.625 (142.8)	14.716 (373.7)	4 1/4 (107.95)	2 1/8 (53.98)	1.560 (39.62) 1.558 (39.57)	9/16 (14.2)	1 1/2 (38.1)	1.968 (49.99) 1.958 (49.73)	15 11/16 (398.46)	2 (50.8)
4 1/2 (114.3)	21 (533.4)	18 11/32 (485.9)	6.406 (162.7)	16.717 (424.6)	4 1/4 (107.95)	2 1/8 (53.98)	1.873 (47.57) 1.871 (47.52)	1 1/16 (17.46)	1 1/2 (38.1)	2.468 (62.69) 2.458 (62.43)	18 23/32 (475.45)	2 (50.8)
5 (127.0)	23 (584.2)	24 1/2 (622.3)	7 5/32 (181.7)	18 21/32 (473.8)	4 1/4 (107.95)	2 1/8 (53.98)	1.873 (47.57) 1.871 (47.52)	1 1/16 (17.46)	1 1/2 (38.1)	2.468 (62.69) 2.458 (62.43)	19 23/32 (500.8)	2 3/4 (69.85)
6 1/16 (154.0)	26 3/4 (679.5)	26 (660.9)	7 25/32 (197.6)	20 9/4 (527.1)	5 21/32 (143.7)	2 5/8 (71.8)	1.875 (47.6) 1.870 (47.5)	1 3/16 (20.6)	2 (50.8)	2.964 (75.3) 2.954 (75.0)	21 23/32 (556.4)	2 3/4 (69.85)

Lug Dimensions Only				
SIZE in (mm)	NO. OF FASTENERS	150# TAPPED		
		THREAD SIZE in (mm)	B.C. in (mm)	B1 in (mm)
2 (50)	4	5/8-11	4 3/4 (120.6)	6 5/8 (168.3)
3 (80)	4	5/8-11	6 (152.4)	9 1/4 (235)
4 (100)	8	5/8-11	7 1/2 (190.5)	10 (254)
-	N/A	N/A	-	NA
6 (150)	8	3/4-10	9 1/2 (241.3)	12 1/4 (311.1)
8 (200)	8	3/4-10	11 3/4 (298.4)	15 1/8 (384.2)
10 (250)	12	7/8-9	14 1/4 (361.9)	18 1/2 (469.9)
12 (300)	12	7/8-9	17 (431.8)	21 1/8 (536.6)
14 (350)	12	1-8	18 3/4 (476.2)	23 1/4 (582.5)
16 (400)	16	1-8	21 1/4 (539.7)	25 (635)
18 (450)	16	1 1/8-8	22 3/4 (577.8)	26 3/4 (679.5)
20 (500)	20	1 1/8-8	25 (635.0)	30 (762)
24 (600)	20	1 1/4-8	29 1/2 (749.3)	36 (914.4)

Gear Operated

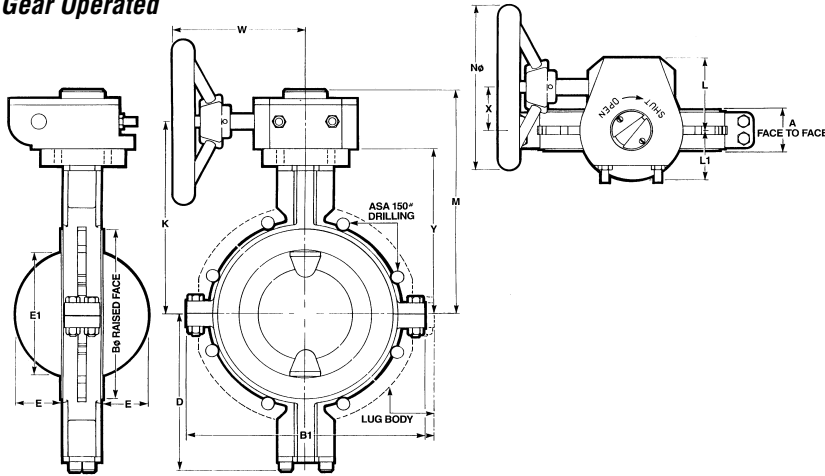

Lever Operated

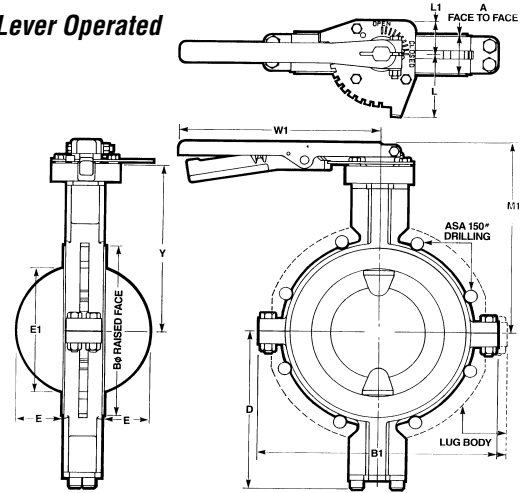

Dimensions for BTV-2000 Wafer and Lug Valves with Gear Operators

SIZE in (mm)	A in (mm)	B0 in (mm)	B1 in (mm)	D in (mm)	E in (mm)	E1 in (mm)	K in (mm)	L in (mm)	L1 in (mm)	M in (mm)	N0 in (mm)	W in (mm)	X in (mm)	Y in (mm)
2 (50)	1 ¹¹ / ₁₆ (42.8)	3 ⁵ / ₈ (92.0)	6 (152.4)	4 ¹⁵ / ₁₆ (125.4)	0.390 (9.90)	1.801 (45.74)	6 ⁵ / ₁₆ (160.3)	3 ¹ / ₈ (79.3)	2 (50.8)	7 ³ / ₈ (187.3)	4 (101.6)	5 ¹ / ₄ (133.3)	1 ³¹ / ₃₂ (50.0)	5 ³ / ₁₆ (131.7)
3 (80)	1 ¹³ / ₁₆ (46.0)	5 (127)	7 ⁷ / ₈ (200.0)	5 ¹³ / ₃₂ (137.3)	0.672 (17.06)	2.586 (65.68)	7 ¹³ / ₃₂ (188.1)	3 ¹ / ₈ (79.3)	2 (50.8)	8 ¹ / ₂ (215.9)	4 (101.6)	5 ¹ / ₄ (133.3)	1 ³¹ / ₃₂ (50.0)	6 ⁹ / ₃₂ (159.5)
4 (100)	2 ¹ / ₁₆ (52.3)	6 (152.4)	8 ³ / ₄ (222.2)	6 ¹³ / ₃₂ (162.7)	0.994 (25.24)	3.487 (88.56)	7 ²⁹ / ₃₂ (200.8)	3 ¹ / ₈ (79.3)	2 (50.8)	9 (228.6)	4 (101.6)	5 ¹ / ₄ (133.3)	1 ³¹ / ₃₂ (50.0)	6 ²⁵ / ₃₂ (172.2)
5 (125)	2 ⁷ / ₃₂ (56.3)	7 ¹ / ₈ (181.0)	10 ⁵ / ₈ (269.9)	8 (203.2)	1 ³ / ₈ (34.9)	4 ⁷ / ₁₆ (112.7)	9 ³ / ₄ (247.7)	3 ⁵ / ₈ (92.0)	2 ¹ / ₂ (63.5)	11 ¹ / ₄ (285.8)	8 (203.2)	6 ³ / ₄ (171.4)	2 ⁹ / ₈ (60.3)	8 ¹ / ₂ (215.9)
6 (150)	2 ⁷ / ₃₂ (56.3)	8 ¹ / ₄ (209.5)	10 ¹ / ₂ (266.7)	8 ¹ / ₂ (215.9)	1.860 (47.24)	5.510 (139.9)	10 ¹ / ₄ (260.3)	3 ⁵ / ₈ (92.0)	2 ¹ / ₂ (63.5)	11 ³ / ₄ (298.4)	8 (203.2)	6 ³ / ₄ (171.4)	2 ⁹ / ₈ (60.3)	9 (228.6)
8 (200)	2 ⁹ / ₈ (60.3)	10 ¹ / ₄ (260.3)	14 (355.6)	9 ⁷ / ₁₆ (239.7)	2.688 (68.27)	7.379 (187.4)	11 ⁹ / ₁₆ (293.6)	4 ³ / ₈ (111.1)	3 (76.2)	13 ¹ / ₂ (324.9)	12 (304.8)	7 ⁷ / ₈ (200.0)	2 ⁵ / ₈ (66.6)	9 ¹⁵ / ₁₆ (252.4)
10 (250)	2 ¹¹ / ₁₆ (68.2)	12 ¹ / ₄ (311.1)	17 (431.8)	11 ²⁹ / ₃₂ (302.4)	3.626 (92.10)	9.569 (243.0)	13 ²⁹ / ₃₂ (353.2)	4 ³ / ₈ (111.1)	3 (76.2)	15 ¹³ / ₁₆ (401.6)	12 (304.8)	7 ⁷ / ₈ (200.0)	2 ⁵ / ₈ (66.6)	12 ¹⁹ / ₃₂ (311.9)
12 (300)	3 ³ / ₃₂ (78.5)	14 ⁹ / ₈ (365.1)	19 ⁵ / ₁₆ (490.5)	12 ⁵ / ₁₆ (328.6)	4.438 (112.7)	11.564 (293.7)	14 ⁷ / ₈ (377.8)	5 (127)	3 (76.2)	16 ⁷ / ₈ (428.6)	12 (304.8)	8 ¹ / ₂ (215.9)	3 (76.2)	13 ⁵ / ₁₆ (338.1)
14 (350)	3 ³ / ₃₂ (78.5)	16 ¹ / ₄ (412.7)	21 ³ / ₄ (552.4)	13 ⁵ / ₁₆ (354.0)	5.016 (127.4)	12.755 (323.9)	16 ⁹ / ₁₆ (411.1)	5 ³ / ₈ (136.5)	3 ¹ / ₂ (88.9)	18 ⁹ / ₁₆ (461.9)	14 (355.6)	12 ¹ / ₄ (311.1)	3 ³ / ₈ (85.7)	14 ⁷ / ₁₆ (366.7)
16 (400)	4 (101.6)	18 ¹ / ₂ (469.9)	25 (635.0)	15 ³ / ₁₆ (385.7)	5.625 (142.8)	14.716 (373.7)	17 ⁹ / ₁₆ (446.0)	6 ⁵ / ₈ (168.2)	3 ¹ / ₂ (88.9)	19 ¹¹ / ₁₆ (500.0)	18 (457.2)	12 ¹ / ₄ (311.1)	4 ³ / ₈ (111.1)	15 ¹ / ₁₆ (398.4)
18 (450)	4 ¹ / ₂ (114.3)	21 (533.4)	26 ³ / ₄ (679.4)	18 ¹¹ / ₃₂ (465.9)	6.406 (162.7)	16.717 (424.6)	20 ¹⁹ / ₃₂ (523.0)	6 ⁵ / ₈ (168.2)	4 (101.6)	22 ² / ₄ (577.8)	18 (457.2)	12 ¹ / ₄ (311.1)	4 ³ / ₈ (111.1)	18 ²³ / ₃₂ (475.4)
20 (500)	5 (127.0)	23 (584.2)	30 (762.0)	24 ¹ / ₂ (622.3)	7 ⁵ / ₃₂ (181.7)	18 ²¹ / ₃₂ (473.8)	21 ¹⁹ / ₃₂ (548.4)	7 ⁵ / ₈ (193.6)	4 (101.6)	23 ⁷ / ₈ (606.4)	18 (457.2)	12 ¹ / ₄ (311.1)	5 ³ / ₄ (136.5)	19 ²³ / ₃₂ (500.8)
24 (600)	6 ¹ / ₁₆ (154.0)	26 ³ / ₄ (679.5)	36 ³ / ₄ (933.5)	26 (660.4)	7 ²⁵ / ₃₂ (197.6)	20 ⁹ / ₄ (527.1)	23 ²⁵ / ₃₂ (604.0)	7 ⁵ / ₈ (193.6)	4 ³ / ₄ (120.7)	26 ¹ / ₃₂ (661.2)	18 (457.2)	12 ³ / ₁₆ (309.6)	5 ³ / ₈ (136.5)	21 ²⁹ / ₃₂ (556.4)

Dimensions for BTV-2000 Wafer and Lug Valves with Lever Operators

SIZE in (mm)	L in (mm)	L1 in (mm)	M1 in (mm)	W1 in (mm)
2 (50)	3 ³ / ₄ (95.2)	2 (50.8)	7 ¹ / ₄ (184.1)	14 (355.6)
3 (80)	3 ³ / ₄ (95.2)	2 (50.8)	7 ⁹ / ₁₆ (192.1)	14 (355.6)
4 (100)	3 ³ / ₄ (95.2)	2 (50.8)	8 (203.2)	14 (355.6)
5 (125)	3 ³ / ₄ (95.2)	2 (50.8)	9 ¹³ / ₁₆ (249.2)	12 (304.8)
6 (150)	3 ³ / ₄ (95.2)	2 (50.8)	10 ⁵ / ₁₆ (261.9)	14 (355.6)
8 (200)	3 ³ / ₄ (95.2)	2 (50.8)	11 ¹ / ₄ (285.7)	14 (355.6)

Gear Operators

VALVE SIZE in (mm)	GEAR MODEL
2 (50)	MX
3 (80)	MX
4 (100)	MX
5 (125)	MZ
6 (150)	MZ
8 (200)*	MV
10 (250)*	MV
12 (300)*	MY
14 (350)*	MA
16 (400)*	MB
18 (450)*	MB
20 (500)	MC
24 (600)	MC

All dimensions are approximate and for illustration purposes only. For exact dimensions request certified dimensional prints.

*Normally gear operated due to safety and torque requirements.

Technical Information

BTV-2000 Valve Weights in Pounds (Kilograms)													
SIZE - in. (mm)	2 (50)	3 (80)	4 (100)	5 (125)	6 (150)	8 (200)	10 (250)	12 (300)	14 (350)	16 (400)	18 (450)	20 (500)	24 (600)
	<u>lbs</u> (kg)	<u>lbs</u> (kg)	<u>lbs</u> (kg)	<u>lbs</u> (kg)	<u>lbs</u> (kg)	<u>lbs</u> (kg)	<u>lbs</u> (kg)	<u>lbs</u> (kg)	<u>lbs</u> (kg)	<u>lbs</u> (kg)	<u>lbs</u> (kg)	<u>lbs</u> (kg)	<u>lbs</u> (kg)
Wafer	<u>13.5</u> (6.1)	<u>16.5</u> (7.5)	<u>21.5</u> (9.7)	<u>28</u> (12.7)	<u>37</u> (16.8)	<u>51</u> (23.1)	<u>88</u> (39.9)	<u>114</u> (51.7)	<u>235</u> (106.6)	<u>280</u> (127.0)	<u>405</u> (183.7)	<u>515</u> (233.6)	<u>1000</u> (453)
Lug	<u>17</u> (7.7)	<u>24</u> (10.9)	<u>32</u> (14.5)	N/A	<u>51</u> (23.1)	<u>74</u> (33.6)	<u>124</u> (56.2)	<u>174</u> (78.9)	<u>275</u> (124.7)	<u>370</u> (167.8)	<u>490</u> (222.3)	<u>618</u> (280.3)	<u>1370</u> (621.4)

BTV-2000 Manual Operator Weights in Pounds (Kilograms)													
SIZE - in. (mm)	2 (50)	3 (80)	4 (100)	5 (125)	6 (150)	8 (200)	10 (250)	12 (300)	14 (350)	16 (400)	18 (450)	20 (500)	24 (600)
	<u>lbs</u> (kg)	<u>lbs</u> (kg)	<u>lbs</u> (kg)	<u>lbs</u> (kg)	<u>lbs</u> (kg)	<u>lbs</u> (kg)	<u>lbs</u> (kg)	<u>lbs</u> (kg)	<u>lbs</u> (kg)	<u>lbs</u> (kg)	<u>lbs</u> (kg)	<u>lbs</u> (kg)	<u>lbs</u> (kg)
Locking Lever	<u>5.0</u> (2.3)	<u>5.0</u> (2.3)	<u>5.0</u> (2.3)	<u>5.0</u> (2.3)	<u>5.0</u> (2.3)	<u>5.0</u> (2.3)	N/A	N/A	N/A	N/A	N/A	N/A	N/A
Gear	<u>9.0</u> (4.1)	<u>9.0</u> (4.1)	<u>9.0</u> (4.1)	<u>15</u> (6.8)	<u>15</u> (6.8)	<u>30</u> (13.6)	<u>30</u> (13.6)	<u>30</u> (13.6)	<u>40</u> (18.1)	<u>64</u> (29.0)	<u>64</u> (29.0)	<u>76</u> (34.5)	<u>76</u> (34.5)

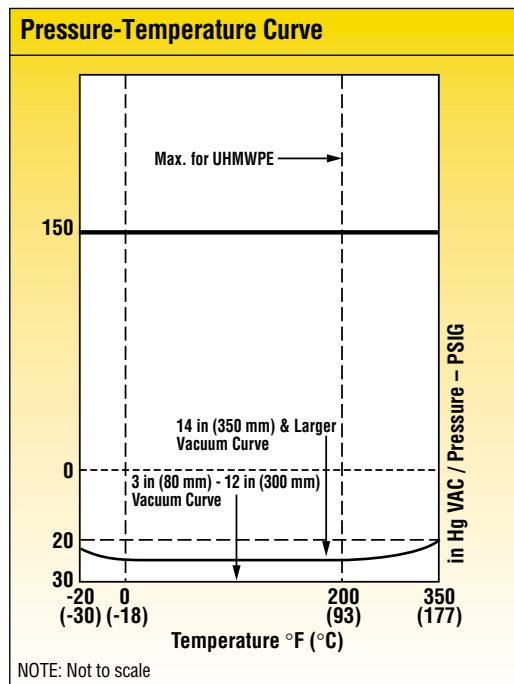

BTV-2000 Butterfly Valve Parts List

Item	Description and Material of Construction	No. Required for these Sizes												
		Size	2	3	4	5	6	8	10	12	14	16	18	20
1	Body <i>ASTM A395 Ductile Iron</i>		●	●	●	●	●	●	●	●	●	●	●	●
1A*	Hex. Hd. Cap Screw <i>B7 ASTM A193</i>		●	●	●	●	●	●	●	●	●	●	●	●
1B*	Hex Nut <i>2H ASTM A194</i>		●	●	●	●	●	●	●	●	●	●	●	●
1C	Bushing <i>Steel</i>		●	●	●	●	●	●	●	●	●	●	●	●
2	Disc: <i>DIPA^a, Alloy; or CDPE^a</i>		●	●	●	●	●	●	●	●	●	●	●	●
3*	Retainer Plate <i>Zinc Plated Steel</i>		●-1-●	●	●	●	●	●	●	●	●	●	●-1-●	●
4	Soc. Hd. Cap Screw <i>Zinc Plated Steel</i>		●	●	●	●	●	●	●	●	●	●	●	●
4A*	Soc. Hd. Cap Screw <i>Zinc Plated Steel</i>		●-2-●	●	●	●	●	●	●	●	●	●	●	●
5*	Gland-Top <i>Stainless Steel</i>		●	●	●	●	●	●	●	●	●	●	●	●
5A*	"O" Ring Inboard <i>Viton</i>		●	●	●	●	●	●	●	●	●	●	●	●
5B*	"O" Ring Outboard <i>Viton</i>		●-1-●	●	●	●	●	●	●	●	●	●	●	●
6*	Spring <i>Stainless Steel</i>		●-1-●	●	●	●	●	●	●	●	●	●	●	●
7*	Bearing <i>PTFE filled composite</i>		●-1-●	●	●	●	●	●	●	●	●	●	●-4-●	●
8*	Ring-Stem Wedge <i>Stainless Steel</i>		●-1-●	●	●	●	●	●	●	●	●	●	●	●
9*	Ring-Stem Compression <i>Silicone (Viton Optional)</i>		●-1-●	●	●	●	●	●	●	●	●	●	●	●
10*	Liner <i>Sentinel™ (Durlon II, PTFE or UHMWPE)</i>		●	●	●	●	●	●	●	●	●	●	●	●
11*	Seat Energizer <i>Silicone (Viton Optional)</i>		●	●	●	●	●	●	●	●	●	●	●	●
12*	Gland-Bottom <i>Stainless Steel</i>		○	○	●	●	●	●	●	●	●	●	●	●
13	Plate-Mounting <i>Steel</i>		●	●	●	●	●	●	●	●	●	●	●	●
14	Stem-Extension (4" and 6" Sizes Only) <i>Stainless Steel</i>		○	○	●-1-●	●	○	○	○	○	○	○	○	○
15*	Spacer <i>Stainless Steel</i>		●	●	●	●	●	●	●	●	●	●	●	●
16	Bracket <i>Steel</i>		○	○	○	○	○	○	○	○	○	○	○	●-1-●
17	Stud <i>Stainless Steel</i>		○	○	○	○	○	○	○	○	○	○	○	●-1-●
18	Hex Nut <i>Stainless Steel</i>		○	○	○	○	○	○	○	○	○	○	○	●-5-●
19	Washer <i>Stainless Steel</i>		○	○	○	○	○	○	○	○	○	○	○	●-2-●
20	Washer <i>PTFE</i>		○	○	○	○	○	○	○	○	○	○	○	●-2-●

a. Disc: DIPA-PFA encapsulated nickel plated ductile iron insert. CDPE-UHMWPE encapsulated CD4Mcu insert
 *Recommended spare parts available only as kit.

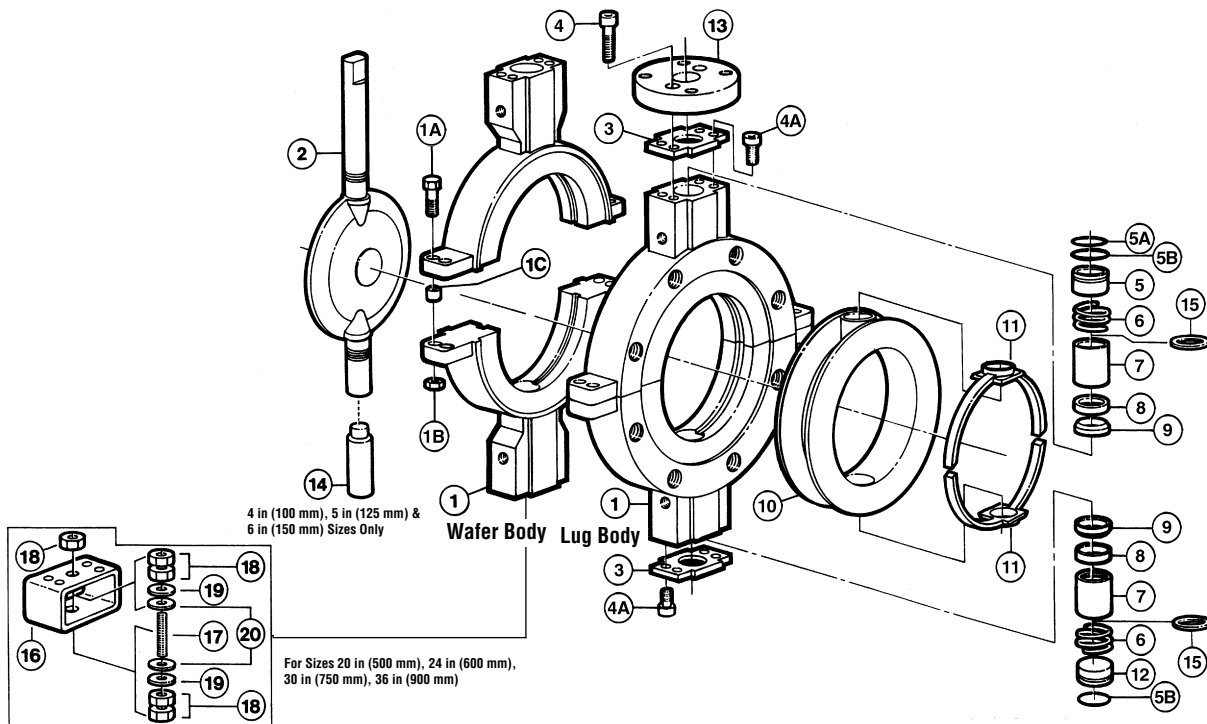

Flowserve Puts You In Control

Choose from a complete line of Automax® Valve Automation Equipment for precise proportioning and on-off control.



A specialist in complete automation systems, Flowserve markets a broad line of rack and pinion, heavy duty, electric and linear actuators. In addition, a comprehensive line of engineered special control circuits, solenoid valves, limit switches, positioners and actuator mounting kits is offered.

Automax rack & pinion actuators incorporate advanced materials and construction for long trouble-free life.

- Precision-extruded hard anodized aluminum body and pistons (PTFE impregnated).
- Massive, one-piece pinion for extra strength.
- Double-acting and spring return.
- Torque range from 60 in/lbs to 40,000 in/lbs.

For more information about Durco valves and the complete line of Automax automation equipment and systems, contact your local Flowserve sales office or authorized stocking distributor.

Design Changes

In order to follow the Flowserve commitment to continuous improvement, we reserve the right to change product and performance specifications without notice.

Selection, Installation, Operation and Maintenance

Although Flowserve can, and often does, provide general guidelines, it is obviously not possible to provide application specific data and warnings for all conceivable applications. The purchaser/end user must therefore assume the ultimate responsibility for the proper selection, installation, operation and maintenance of the products. Read the appropriate IOM available from Cookeville, TN 38501 before installing, operating or repairing any valve. The purchasers/end user should train its employees and/or contractors in the safe use of the Flowserve products in connection with the purchaser's manufacturing processes.

How To Specify BTV/BUV Lined Butterfly Valves

		Size	Type	Liner	Style	Body Materials	Stem & Disc Materials	Operator	Options
		□	□	□	□	□	□	□	□
Valve Size									
Selection	Code	Selection	Code						
2 in (50 mm)	2	14 in (350 mm)	14						
3 in (80 mm)	3	16 in (400 mm)	16						
4 in (100 mm)	4	18 in (450 mm)	18						
5 in (125 mm)	5	20 in (500 mm)	20						
6 in (150 mm)	6	24 in (600 mm)	24						
8 in (200 mm)	8								
10 in (250 mm)	10								
12 in (300 mm)	12								
Type									
Selection	Code								
Butterfly	B								
Liner Material									
Selection	Code								
Sentinel™ (Durlon II)	S								
PTFE	T								
UHMWPE	U								
Body Style - 150# Split Body									
Selection	Code								
Wafer	W								
Lug	L								
Body Material									
Selection	Code								
DCI	4								
D4 (A351 Gr CF8M)	1								
All Sizes									
Stem & Disc Material									
Selection	Code	Selection	Code						
D100	0	DC3	6						
316SS (D4)	1	TIP	7						
D20	2	PFA	8						
DM	3	UHMWPE	9						
DC2	5	254 SMO†	S						
Titanium	T								
Operator Options									
Selection	Code								
10 Position Locking Lever	0								
Enclosed Gear	1								
Pad Lockable Gear	2								
Bare Stem	9								
Energizer Options									
Selection	Code								
Silicone	R								
Viton Energizer & Seals*	V								
EPDM Energizer & Seals	E								
Other Options									
Selection	Code								
DIN PN10	P1								
DIN PN16	P6								
Cleaning Options									
Selection	Code								
Chlorine Cleaning (must use Viton Energizers)	C								
Oxygen Cleaning (cleaning specification number required)	0								
Code Descriptions									
2 = (2) purge ports									
4 = (4) purge ports									
5 = (1) lubrication port									
6 = (2) lubrication ports									

* = Recommended for Chlorine Services
 † = Registered trademark of Avesta AB

Example: 12-B T L 4 8 1-V- - -
 12 in BTV-2000 butterfly valve with PTFE liner; lug design Class 150 drilling, ductile cast iron split body and PFA disc; enclosed gear operator; Viton energizer and seals; no additional options.

D4 = ASTM A351/A744 Gr. CF8M (316 S.S.)	254 SMO = ASTM A744/A351 (CK-3MCuN)
D20 = ASTM A351/A744 Gr. CN-7M (Durimet 20)	Titanium = ASTM B367 Gr. C-2 ³
D100 = ASTM A351/A744 Gr. CD4MCu (Durcomet 100)	PFA = Perfluoroalkoxy polymer
DM = ASTM A494 Gr. M35-2 (Monel 400) ²	PTFE = Tetrafluoroethylene polymer
DCI = ASTM A395 (Ductile Iron)	Sentinel = Modified fluoropolymer
DC2 = ASTM A494 Gr. N-7M (Chlorimet 2)	UHMWPE = Ultra high molecular weight polyethylene
DC3 = ASTM A494 Gr. CW-6M (Chlorimet 3)	TiP = ASTM B367 Gr. TiPd 8A ⁴

1. Registered trademark of Avesta AB
 2. Registered trademark of the International Nickel Company, Inc.
 3. Commercial Titanium
 4. Paladium Stabilized Titanium

How to Specify BTV/BUV Lined Butterfly Valves

PTFE Lined Butterfly Valve – two-piece epoxy coated Ductile Iron body to ASTM A395. Epoxy coating to be electro-static dry powder spray, heat cured. The valve should meet the design requirements of ISO, MSS SP67, API 609 F/F, ASME B16.34 and meet the face to face dimensions of ISO 5752/20, API 609 and MSS SP67 narrow face to face, in all sizes. The one-piece A 395 Ductile iron disc insert shall be electroless nickel plated and encapsulated with a minimum of 1/8 in (3 mm) thick PFA. The liner to be machined with 1/8 in (3 mm) nominal thickness and recessed into valve body. The disc is to have spherically machined hubs and convex edge, while liner should have spherically machined sockets at disc hub interface with a concave seating surface. The seat and primary stem seals shall be energized by a silicone rubber backup member that is the same width as the disc edge and locked into a mating groove in the body. The stem shall have machined convolutions. The convolutions provide an independent and separate Labyrinth seal between the stem and liner and must be live loaded by the use of compressed springs. An atmospheric stem seal shall be provided with separate O-ring seals for the shaft and body bore. Upper and lower stem seal assemblies shall be held in place by a heavy metal plate fastened to the body. Snap rings are not acceptable. Positive stem blow out shall be provided between the disc and top of the shaft in case separation occurs. This stem blow out preventer shall be internal in the neck area and separate from the operator. Provision to drill and tap the neck for leak detection at the top and bottom shall be standard. The interchangeable ISO actuator mounting pad shall be standard. A 10 position epoxy coated lockable locking lever shall be optional on valves 2 in (50 mm) through 6 in (150 mm) and an enclosed worm gear operator optional on all sizes. The valve shall be Durco Series BTV-2000.



Flowserve has the answer to your corrosion resistant, quarter-turn valving needs.

Clockwise from top right.

Durco® BTV-2000

PTFE or UHMWPE lined chemical service valve

Atomac®

Lined ball valves

- ASME/ISO, standard and full port
- Specialty valves
- Valve products and accessories

Durco® SleeveLine®

Non-lubricated, PTFE-sleeved plug valves

- G4 Isolation
- G4E – DIN Mounting Pad
- G4 Marathon™
- TSG4 Severe Service

Durco® T-Line®

Non-lubricated, PTFE-lined plug valves

Big Max® Butterfly

High performance valves

Durco® Microfinish™

Alloy ball valves

Automax®

Valve automation systems

- Actuators
- Controls with smart technology
- Accessories

For more information, contact:



Flowserve Corporation
Flow Control Division
1978 Foreman Drive
Cookeville, Tennessee 38501
Phone: 931 432 4021
Fax: 931 432 3105
www.flowserve.com



Or Consult Your Local Stocking Distributor

Flowserve Ahaus GmbH
Von Braun Straße 19a
D-48683 Ahaus
Germany
Phone: +49 2561 686-0
Fax: +49 2561 686-39

Flowserve Pte. Ltd.
12 Tuas Avenue 20
Republic of Singapore 638824
Phone: 65 862 3332
Fax: 65 862 2800

FCD DVATB0020-00
(Bulletin V-20)
Printed in U.S.A.
February 2005
© Flowserve Corporation